



Bobcat®

AL275

Articulated Loaders



Machine Rating

Lift breakout force (ISO 8313)	37000 N
Lift capacity (ISO 8313)	33000 N
Tipping load, straight (ISO 8313)	2750 kg
Tipping load, articulated at 40° (ISO 8313)	2475 kg

Engine

Make / Model	Kubota V2403-M-DI
Fuel / Cooling	Diesel / Liquid
Power (97/68 EC)	35.9 kW (48.1 HP)
Power (ECE-R24)	35.0 kW (46.9 HP)
Torque at 1700 RPM (ISO 9249)	162.0 Nm
Number of cylinders	4
Displacement	2.4 l
Fuel tank capacity	75.0 l

Weights

Operating weight, standard	3900 kg
Operating weight, high-speed option	3958 kg

Controls

Vehicle steering	Steering wheel
Loader hydraulics tilt and lift	Multi-function joystick with integrated direction-of-travel switch, float position switch and auxiliary control circuit switch.
Auxiliary circuit	Switch on multi-function joystick

Drive System

Transmission type	Variable displacement hydrostatic pump, flange-mounted onto the engine. Two-stage variable displacement motor with power shift on the rear axle reduction gear. High-speed option adds an additional manual transmission shift that can be operated while stationary.
-------------------	---

Standard Features

Rubber-mounted full-vision ROPS* cab with two doors and sliding window on left-hand side	Tilt adjustable steering wheel
Hydraulically cushioned seat with seat belt	Self-locking differentials
Cab heating and air intake filter	Front working lights
Multi-function joystick	Turn direction indicators
Auxiliary hydraulics	Radio pre-installation
Instrumentation	Mitas EM01 tyres
Parking brake	Set of maintenance tools
Intermittent windscreen wipers and washer, front and rear	

* Roll Over Protective Structure (ROPS) – meets requirements of SAE-J1040 and ISO 3471

Options

High-speed travel	Coupler for hydraulic hand-held breaker
FOPS** skylight guard	Open hydraulic return
Mechanical quick-attach system	Anti-theft device
Hydraulic quick-attach system	Hose-rupture safety valves
Backup alarm, automatic	Dunlop SPT9 tyres
Backup alarm, deactivatable	Michelin XMCL tyres
Rear working light	Continental MPT E-70 tyres
Sliding door window on right-hand side	License plate illumination
Rotating beacon	Load hook integrated in quick-attach system
Air conditioning	Bucket ride control
Air-cushioned seat with lumbar support	TUV-approval for Germany
Height and tilt adjustable steering wheel	Biodegradable hydraulic oil (Panolin)
Electric refuelling pump	Super-light material bucket

Dimensions

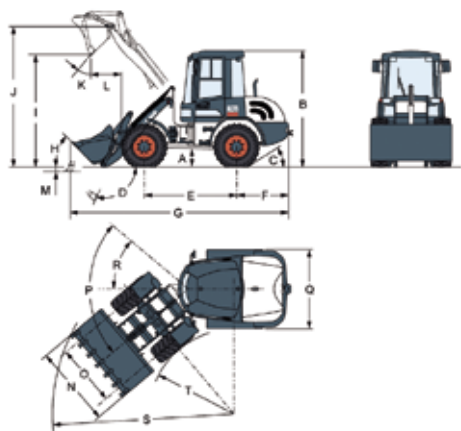

(A) Ground clearance	410 mm
(B) Height with operator cab	2610 mm
(C) Angle of departure	35°
(D) Max. tilt angle below ground level	120°
(E) Wheelbase	1950 mm
(F) Rear overhang	1175 mm
(G) Length with standard bucket	4780 mm
(H) Rollback at ground position	50°
(I) Dump height with standard bucket	2515 mm
(J) Height to bucket hinge pin	3120 mm
(K) Dump angle at maximum height	45°
(L) Dump reach at maximum height	580 mm
(M) Digging depth	70 mm
(N) Width over standard bucket	1700 mm
(O) Track over standard tyres	1330 mm
(P) Max. articulation angle	80°
(Q) Width over standard tyres	1650 mm
(R) Articulation angle	±40°
(S) Turning radius at standard bucket	3870 mm
(T) Turning radius at tyres	1830 mm

Attachments

Loading bucket
Loading bucket with grapple
Earth bucket
Light material bucket
Super-light material bucket
Multi-purpose bucket
Side-dump bucket
High-tip bucket
Quarry bucket
Load hook attachable on pallet forks
Crane jib
Front ripper
Pallet forks



www.bobcat.eu